

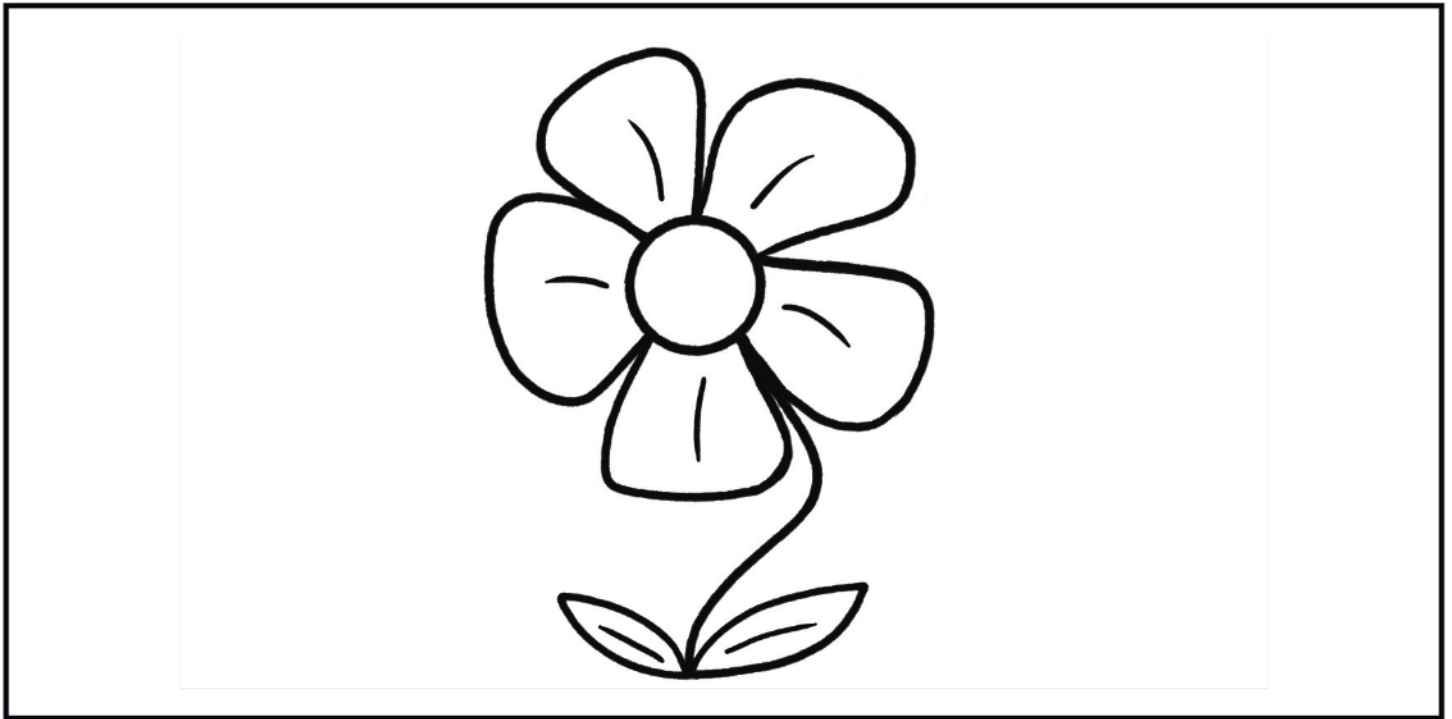

Unit 3 Lesson 1

Big Truth – Living things eat, grow, and make more of themselves.

Color in the picture below.



Circle the  if the thing is living. Circle the  if the thing is not living.

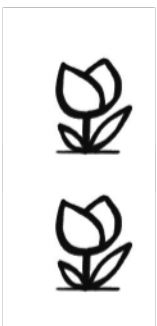

bear

book



blanket



bumblebee

Draw a picture of something that is alive.

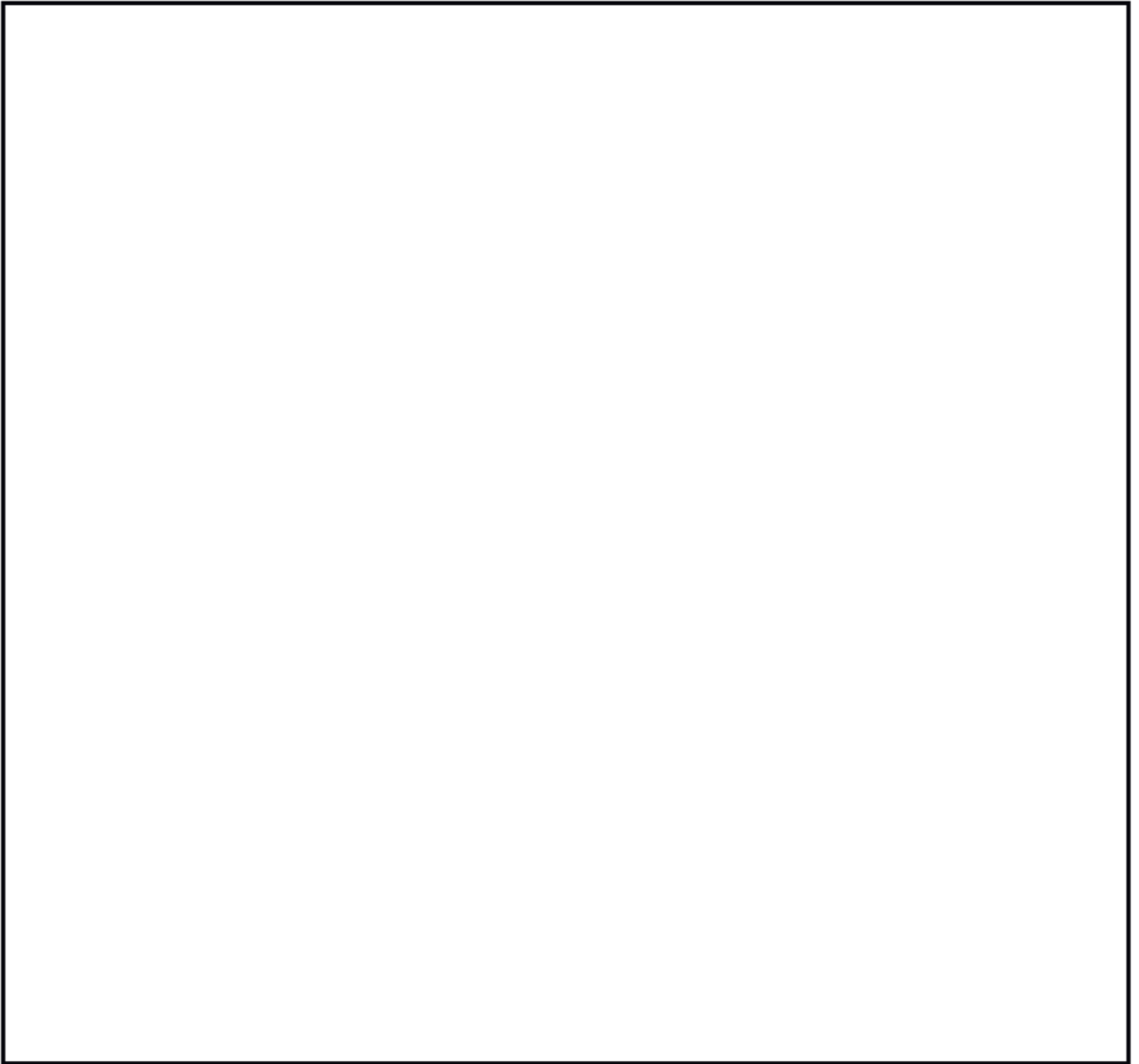

Tell the adult with you the three things the object in your picture can do that shows you it is living.

1. _____

2. _____

2. _____

Scripture Memory

Colossians 1:16

Through His power all things were made.

Game: I'm Thinking of...

- Remind your child of the big truth for today – living things eat, grow, and make more of themselves.
- Play the guessing game “I’m thinking of...” Give two or three clues to describe what you are thinking of. Make sure that one of the clues is whether that thing is living or not living.
- Let your child guess what you are thinking of.
- Switch roles and have your child describe what he or she is thinking of. Remind him or her to tell you whether that thing is living or not living.

Unit 3 Lesson 2

Big Truth – All living things have information.

Color in the pictures below. Then tell the adult with you what information each object tells you.

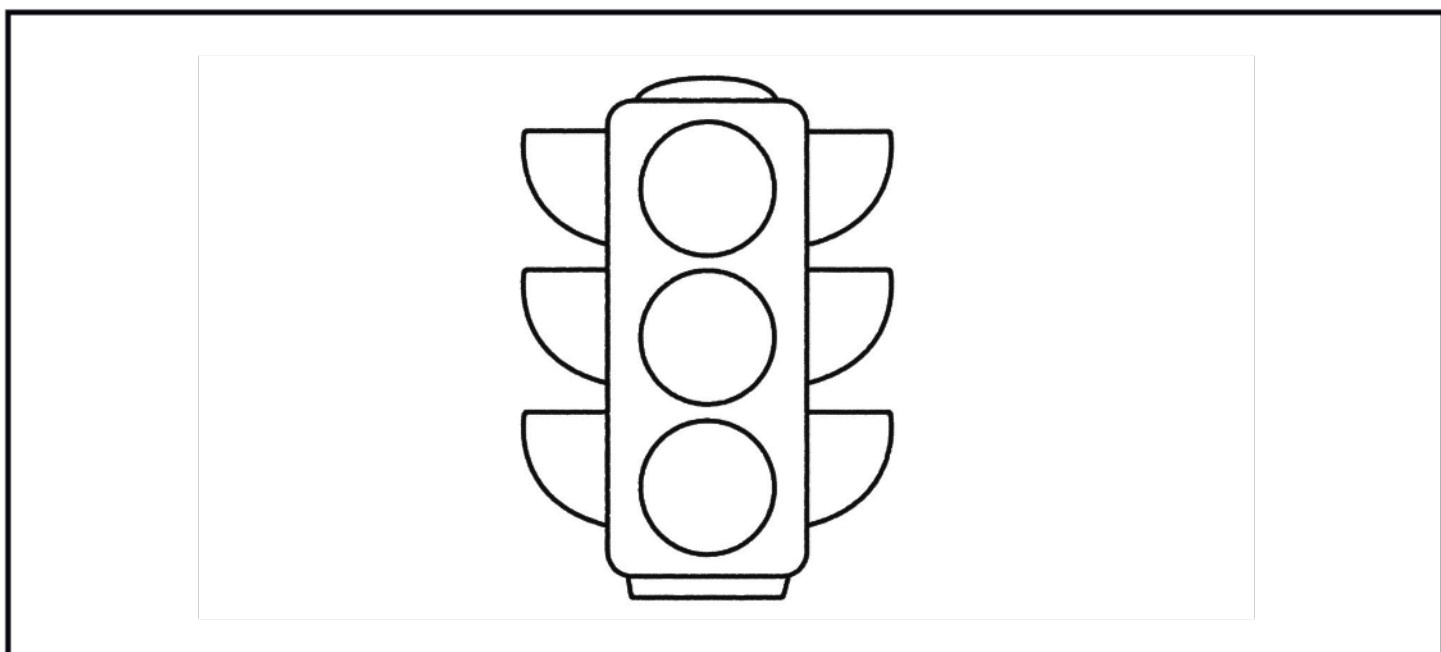
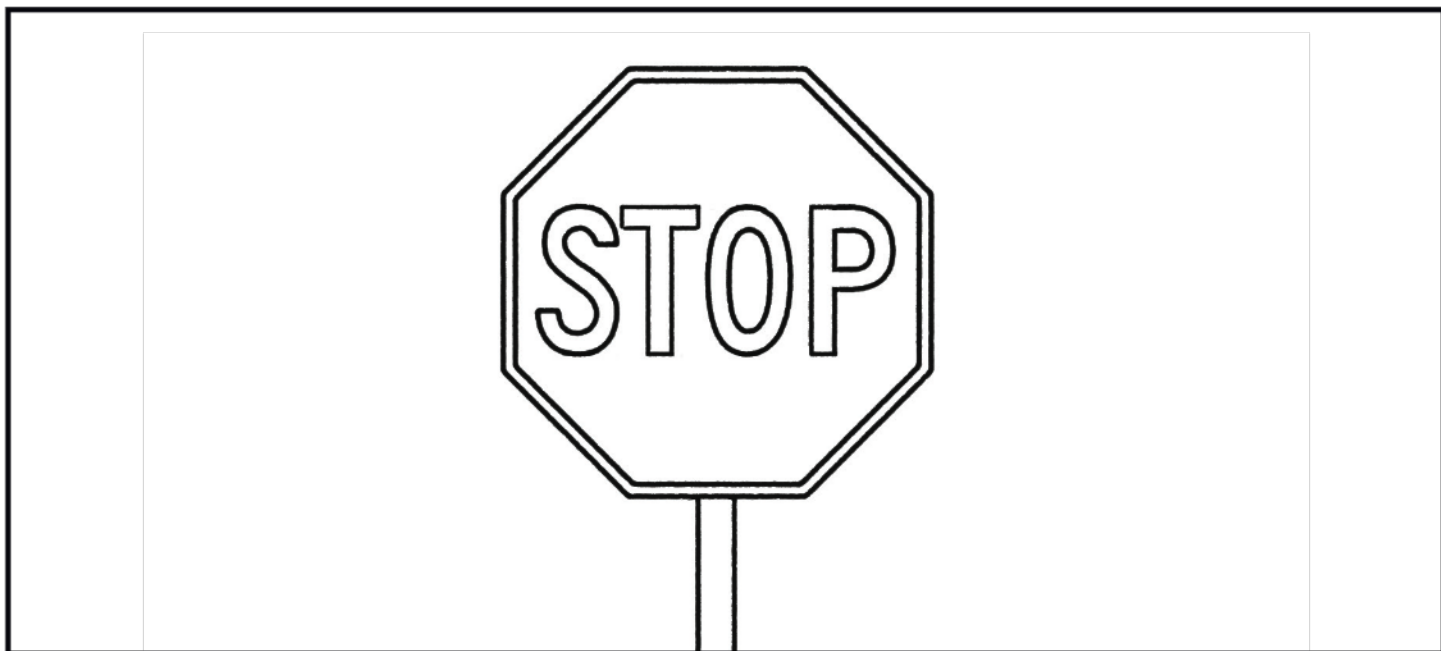



Scripture Memory

Colossians 1:16

Through His power all things were made.

Game: Information in Me

- Remind your child of our big truth for today – life has information.
- Remind your child that this information is like a big plan that tells her body how tall to grow, what color and kind of hair to grow, the shape of her nose, the color of her eyes, etc.
- Sit on the floor across the room from your child.
- Roll a soft ball to him. When he catches it, have him jump up and tell one thing that the information in his body told it to do (hair color, eye color, etc.).
- Have your child roll the ball back to you and say, “That is the information in me!”
- Repeat this activity 3–4 times.

Unit 3 Lesson 3

Big Truth – Information always comes on purpose.

Color in the picture below.



Color in the  if the thing came to be on purpose.

Color in the  if the thing came to be by accident.

  traffic light

  book

  baby

Draw a picture of yourself.

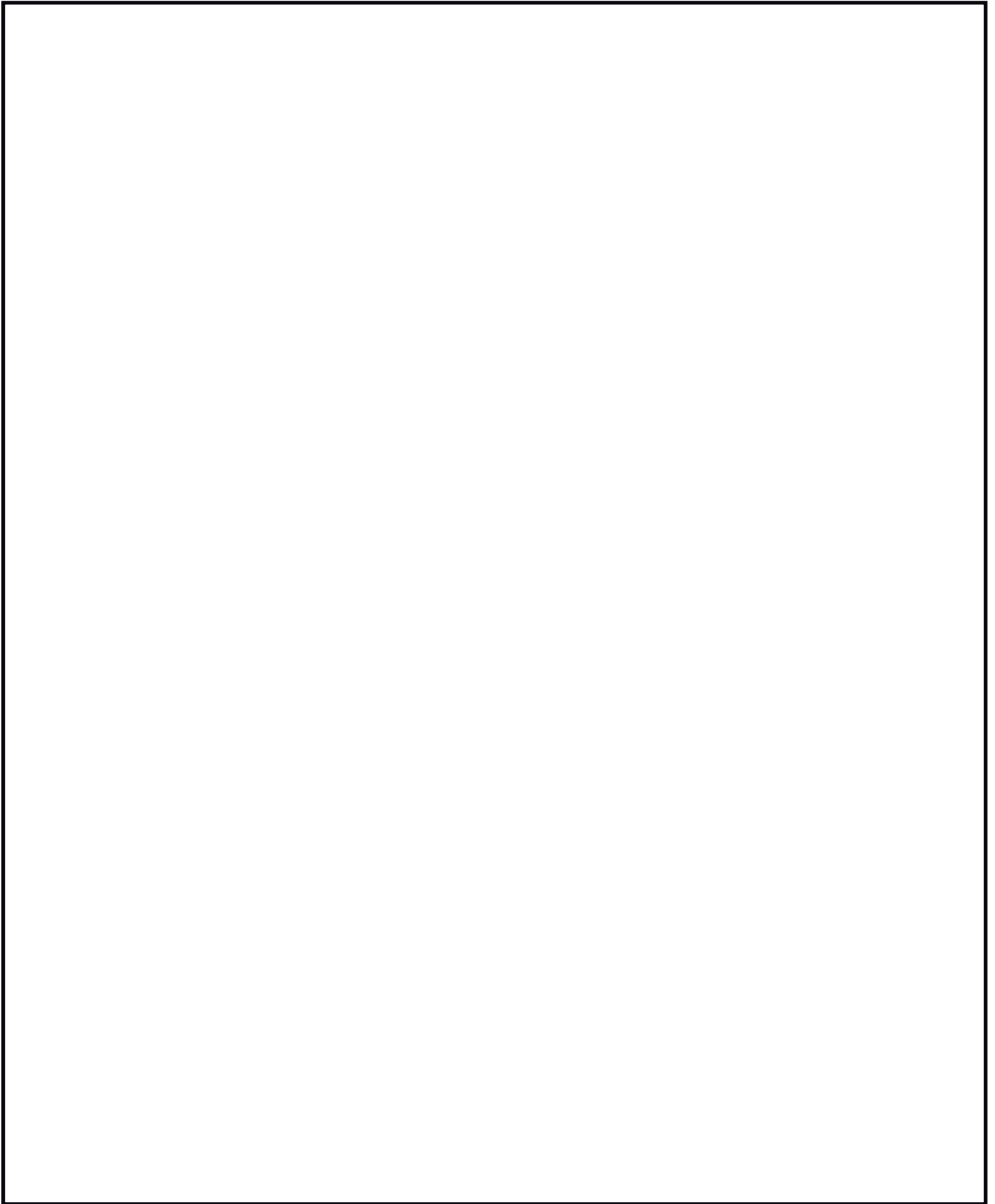

Practice saying these truths with the adult with you.

- Living things eat, grow, and make more of themselves.
- All living things have information.
- Information always comes on purpose.

Remember:

- You are alive.
- Your body has information.
- You came to be on purpose!

Scripture Memory

Colossians 1:16

Through His power all things were made.

Game: Accident or on Purpose?

- Remind your child of the three truths we have learned about life:
 - Living things eat, grow, and make more of themselves.
 - All living things have information.
 - Information always comes on purpose.
- Explain that you will read a list of names. Every time you read the name of someone who came about on purpose, have your child hop up and down on one foot. (Hint: Every person on the list came about on purpose. There will be a lot of hopping!)

Names

- Dad
- Mom
- *child's name*
- *siblings' names*
- Grandma
- Grandpa
- *aunts' and uncles' names*
- *cousins' names*
- *friends' names*

Unit 3 Lesson 4

Big Truth – Things with a purpose have a creator.

Color in the pictures below. Then tell the adult with you who created each thing.

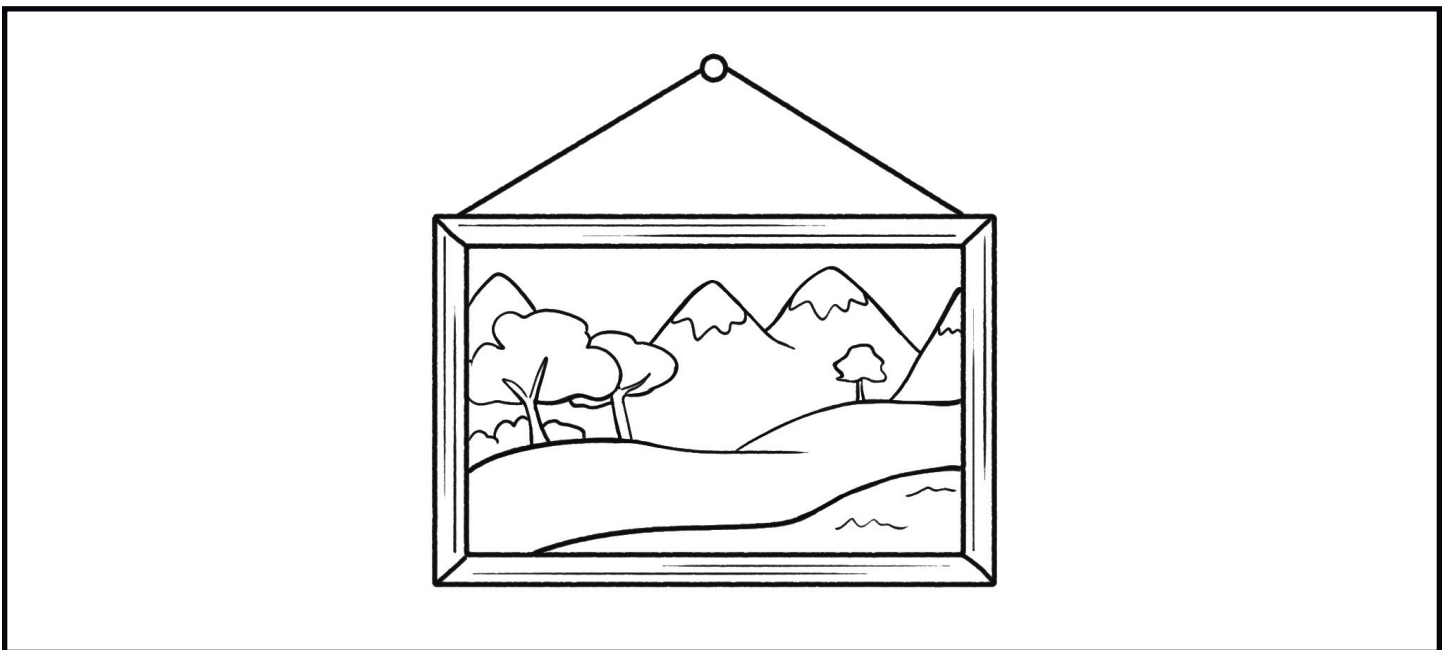
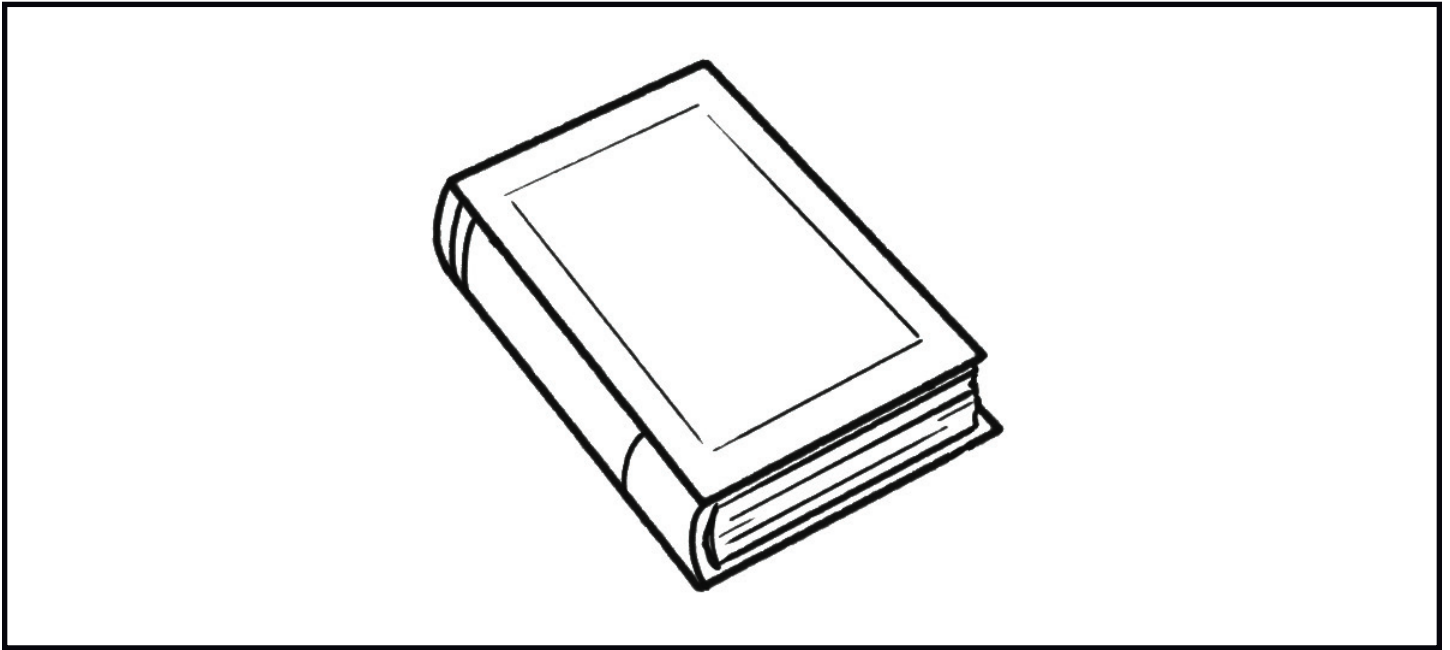

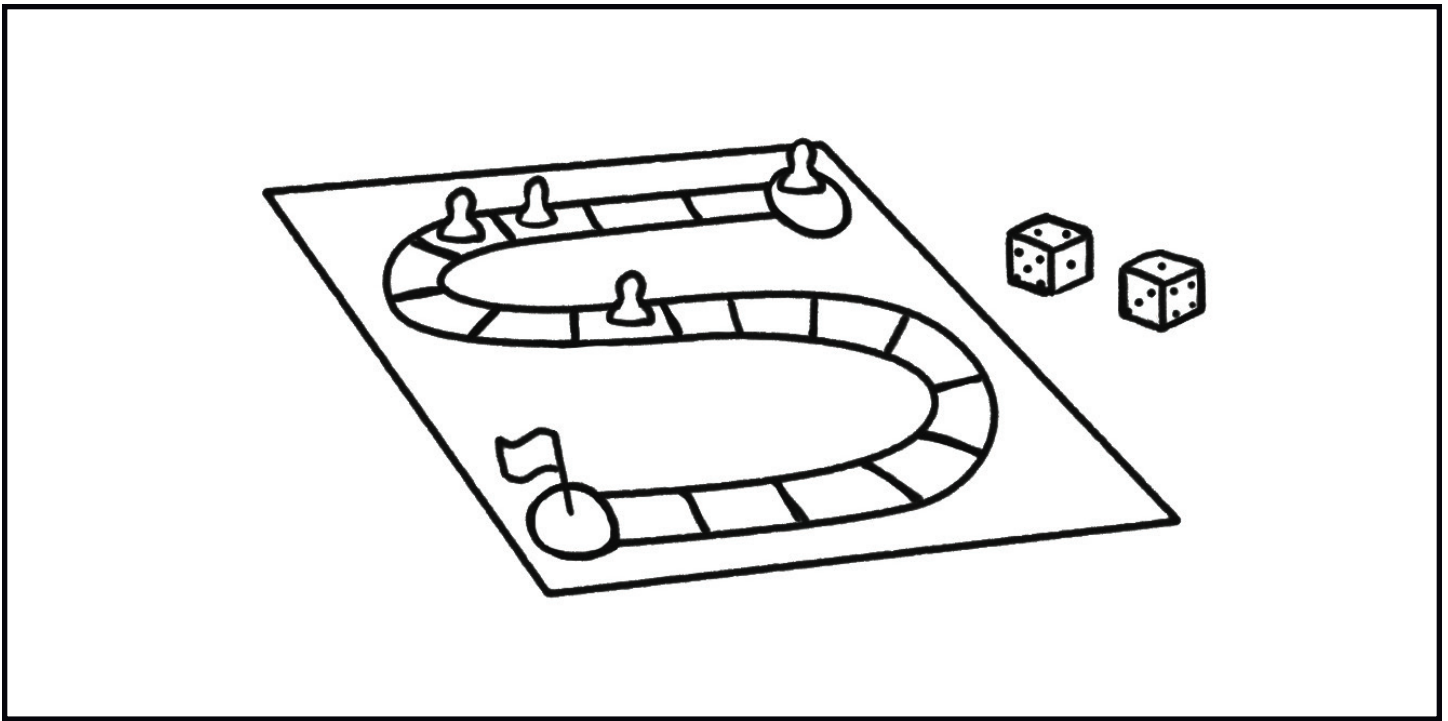

Scripture Memory

Colossians 1:16

Through His power all things were made.

Game: “Who created this?” Charades

- Take out a whiteboard and marker or paper and pencil.
- Explain to your child that you are going to draw an object. Your child will need to guess what the object is and then explain who created/designed that object.
- If your child is old enough, you can switch the roles of drawer and guesser. You can also time yourselves to see how quickly you can correctly guess and explain who the creator/designer is.

Sample things to draw:

- book
- clock
- phone
- car
- table
- stuffed animal
- basketball
- airplane
- bread
- crayon

Song: "Created" (to the tune of "Row, Row, Row Your Boat")

We eat and grow and reproduce.
How did we get so smart?
It's programmed in our DNA;
Information from the start.

We see design and purpose in
Each and every part.
And with design we know that there's
A creator at the heart.

Unit 3 Lesson 5

Big Truth – God is the creator.

Color in the pictures that show things God created.

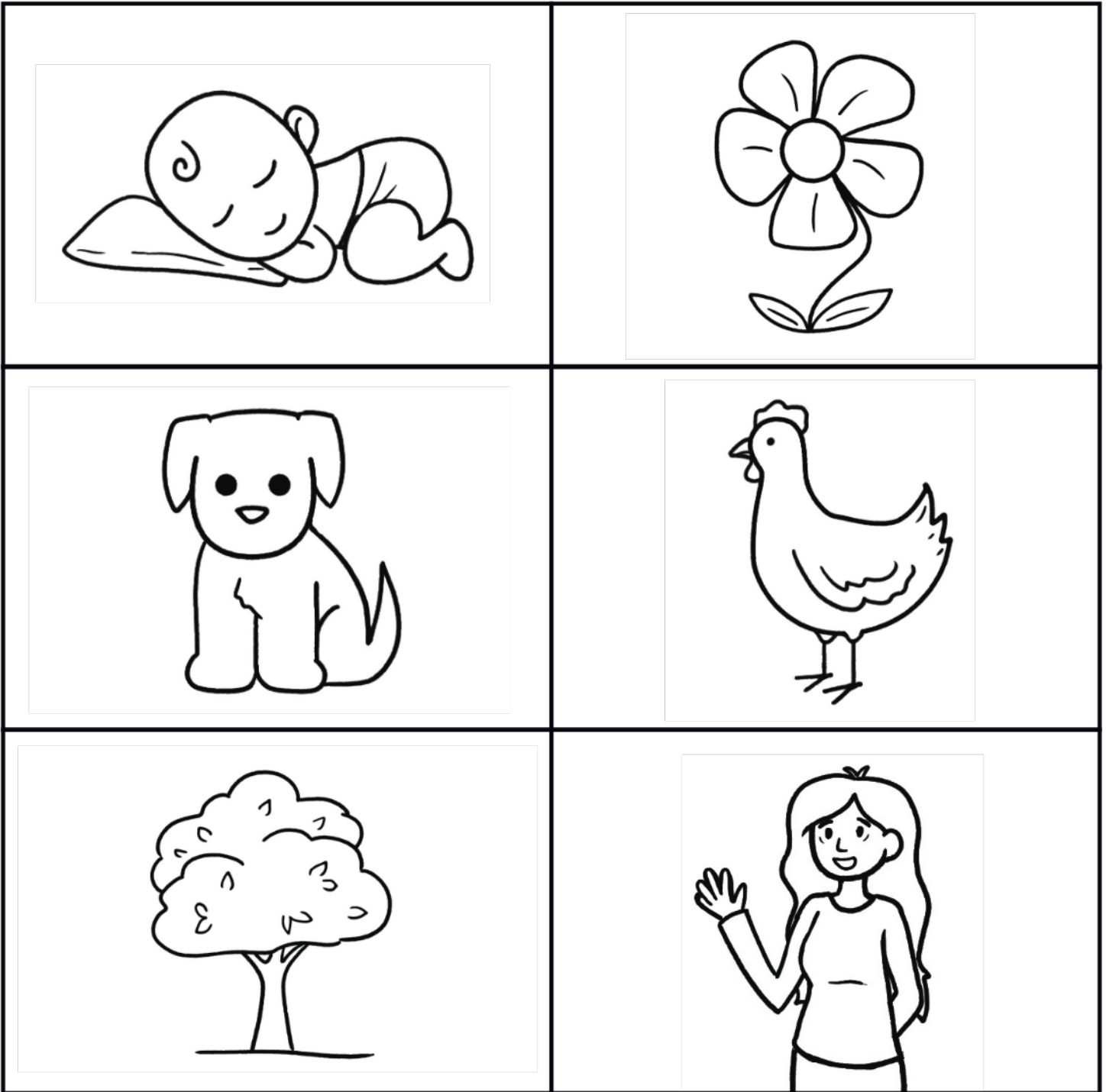

Draw a picture of some living thing God created.

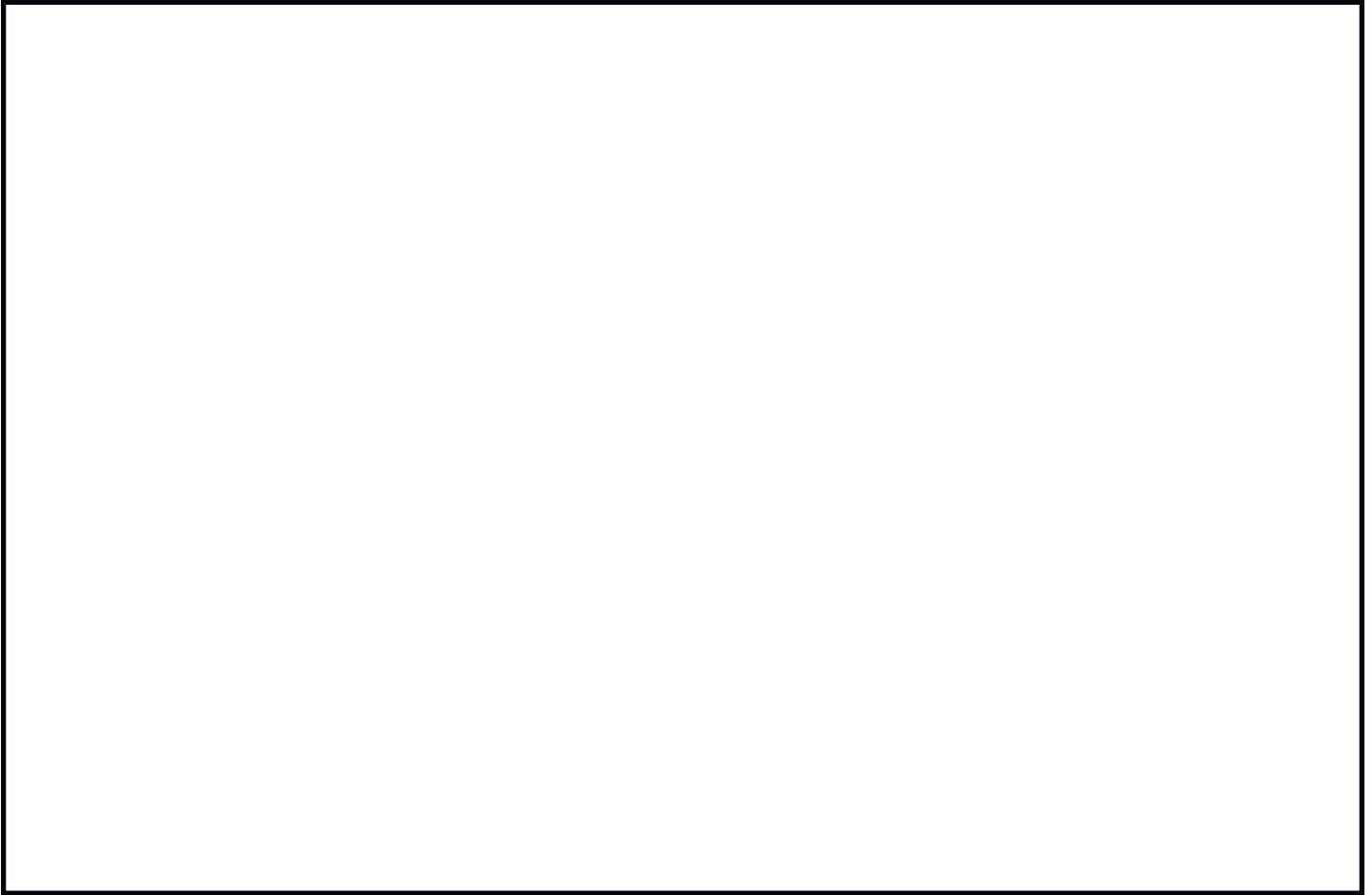

Tell the adult with you what you drew.

Scripture Memory

Colossians 1:16

Through His power all things were made.

Game: Hot Potato

- Sit on the floor, several feet away from your child.
- Roll a ball back and forth while playing music.
- Stop the music abruptly.
- Whoever has the ball at the time needs to say one living thing that God created.

Unit 4 Lesson 1

Big Truth – Humans are God’s image-bearers.

Color in the pictures that show image-bearers.

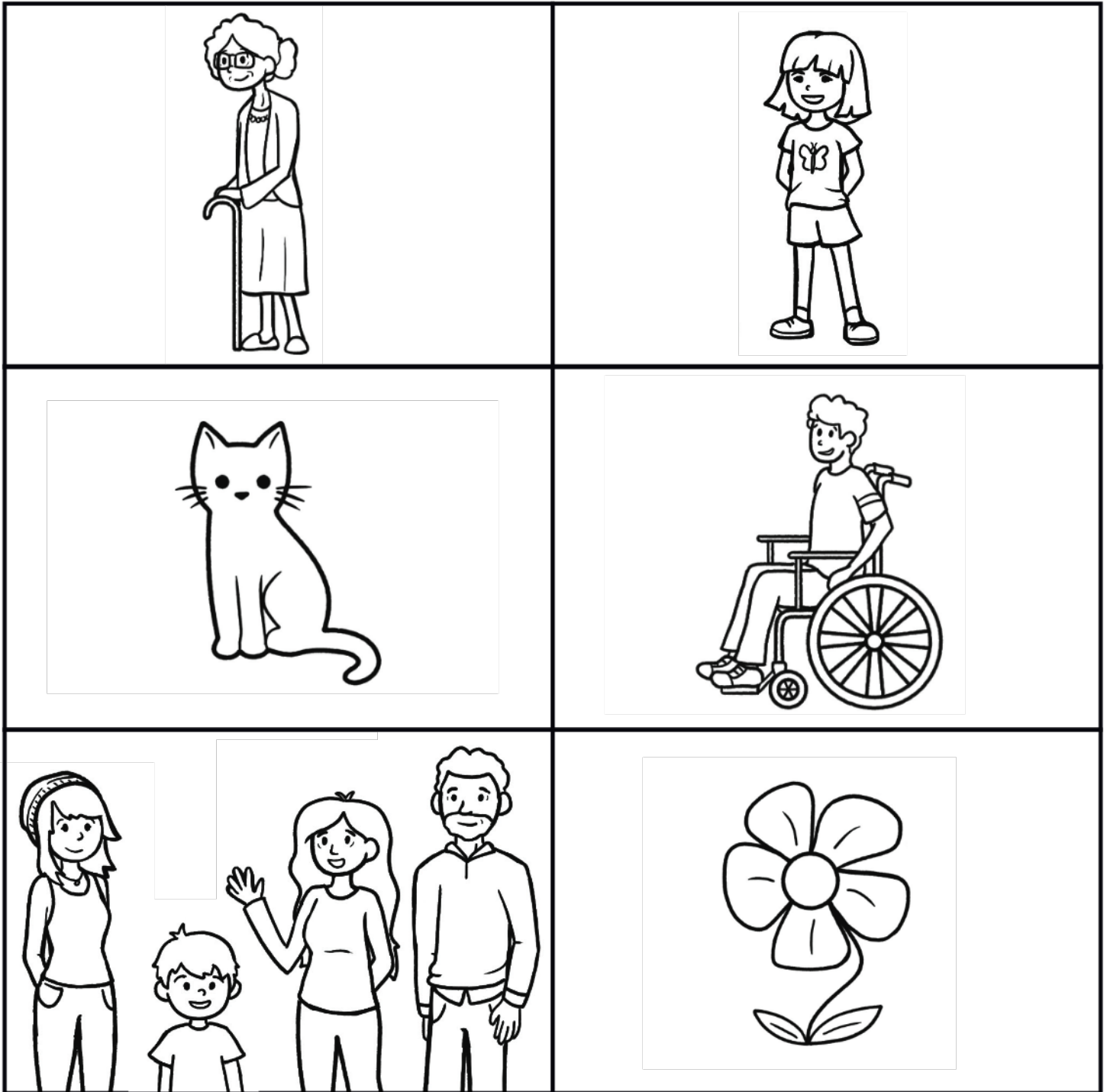

Draw a picture of two image-bearers you know.

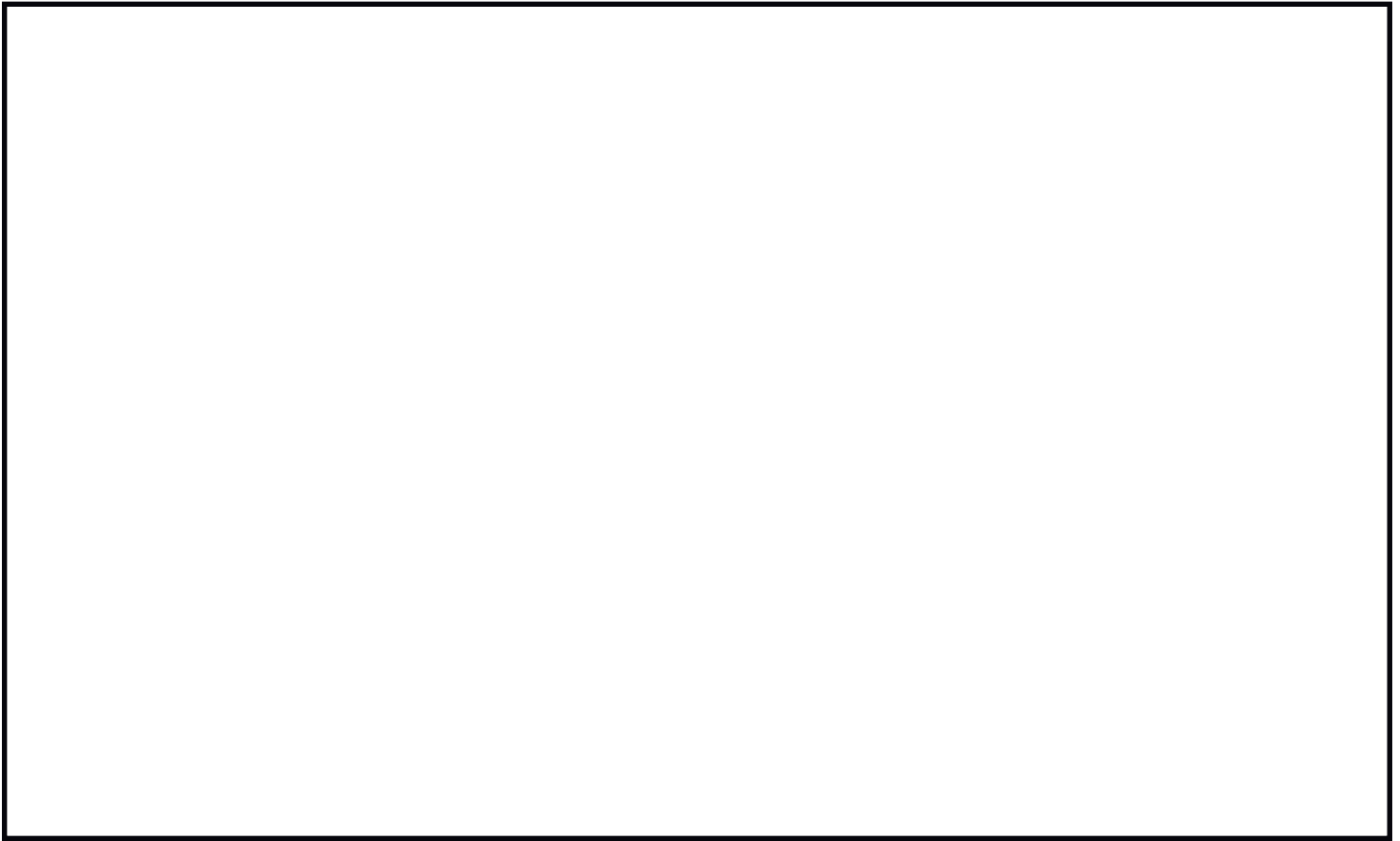

Tell the adult with you the names of the image-bearers you drew.

Scripture Memory

Genesis 1:27

So God created human beings in his image. In the image of God he created them. He created them male and female.

Craft: Image-Bearer Poster

- Take several old magazines, child-safe scissors, poster paper, and glue. (If you prefer not to use magazines, you can print off family photos.)
- Tell your child that you are going to create an image-bearer poster.
- Together, cut out pictures of image bearers you find in the magazines (or family photos).
- Glue the pictures on the poster paper.
- Once dried, hang the poster up and have your child explain what makes each person on the poster an image-bearer. (Being human makes them image-bearers.)

Unit 4 Lesson 2

Big Truth – God made boy image-bearers and girl image-bearers.

Color in the picture below.

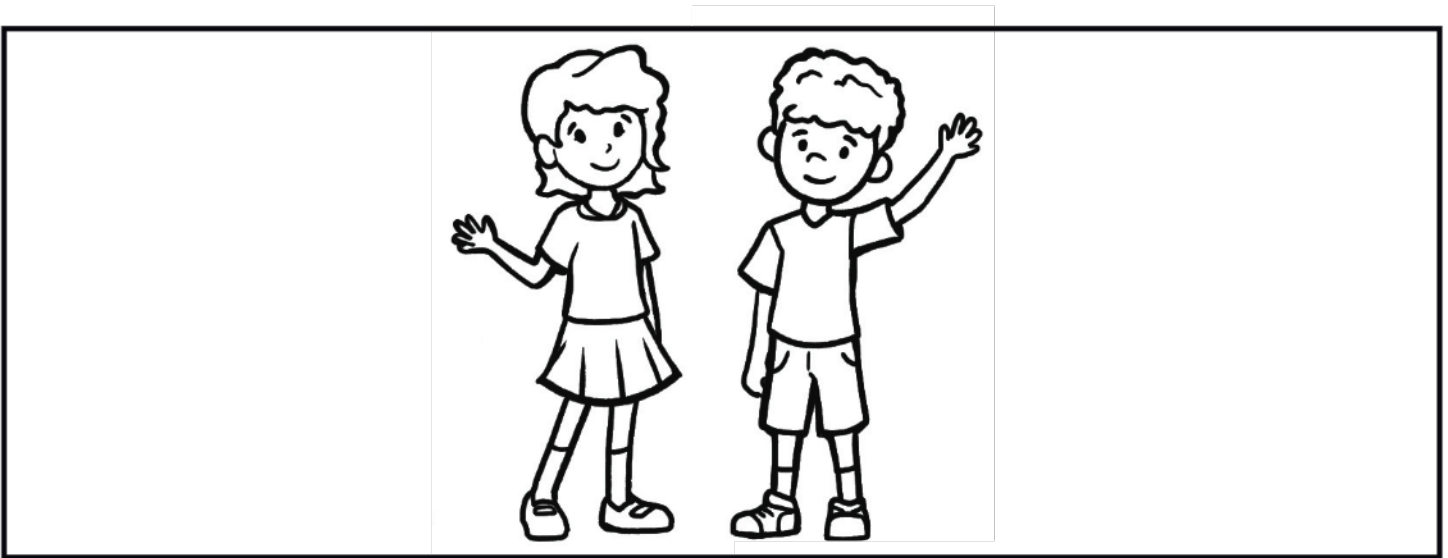

Circle all of the pictures that show things both boy image-bearers and girl image-bearers can like.

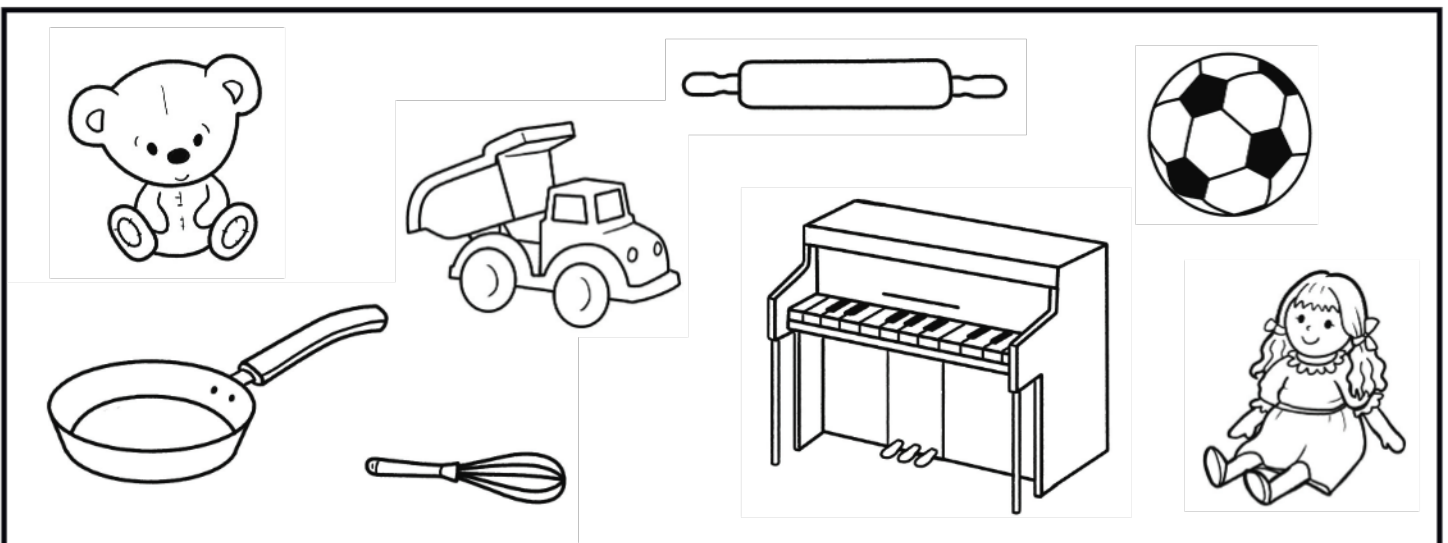

Draw a picture of a girl image-bearer and a boy image-bearer you know.

A large, empty rectangular box with a black border, intended for drawing. It is divided into two horizontal sections by a single line across the middle.

Tell the adult with you the name of the girl image-bearer and boy image-bearer you know. Then tell one thing you are thankful for about each of them.

Girl Image-Bearer

Boy Image-Bearer

Scripture Memory

Genesis 1:27

So God created human beings in his image. In the image of God he created them. He created them male and female.

Game: I am an Image-Bearer

- Remind your child of our big truth for today – God made boy image-bearers and girl image-bearers.
- Sit on the floor across the room from your child.
- Roll a soft ball to her. When she catches it, have her jump up and tell one thing that she is good at.
- Have her roll the ball back to you and say, “I am a girl image bearer!” (If male, have your child say, “I am a boy image bearer!”)
- Repeat this activity 3–4 times.

Unit 4 Lesson 3

Big Truth – Humans are both body and soul.

Color in the pictures below.

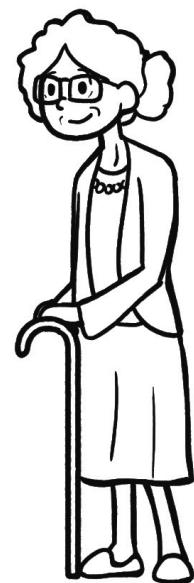
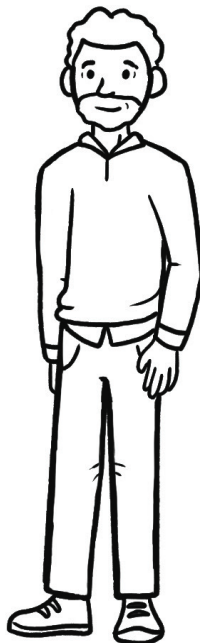

Explain to the adult with you, if our bodies are changing, what makes us still the same person.

Scripture Memory

Genesis 1:27

So God created human beings in his image. In the image of God he created them. He created them male and female.

Game: Pin the Spot on the Person

- For this activity you will need a large picture of your child's face, colored dot stickers, and a blindfold.
- Tape the picture of your child to the wall.
- Put the blindfold on your child and spin him around several times.
- Put a sticker in his hand and have him place it on his picture.
- Take the blindfold off. Have your child identify the part of his face where he placed the sticker. Then have him explain how this part of his face is different now than when he was born.
- Ask your child, "If your _____ [nose, eyes, mouth, etc.] is different now than when you were born, what makes you still the same person?" He should reply with, "I am both body and soul."
- Repeat this activity, but be sure the spinning does not make your child nauseous.

Unit 4 Lesson 4



Big Truth – All humans miss the mark.

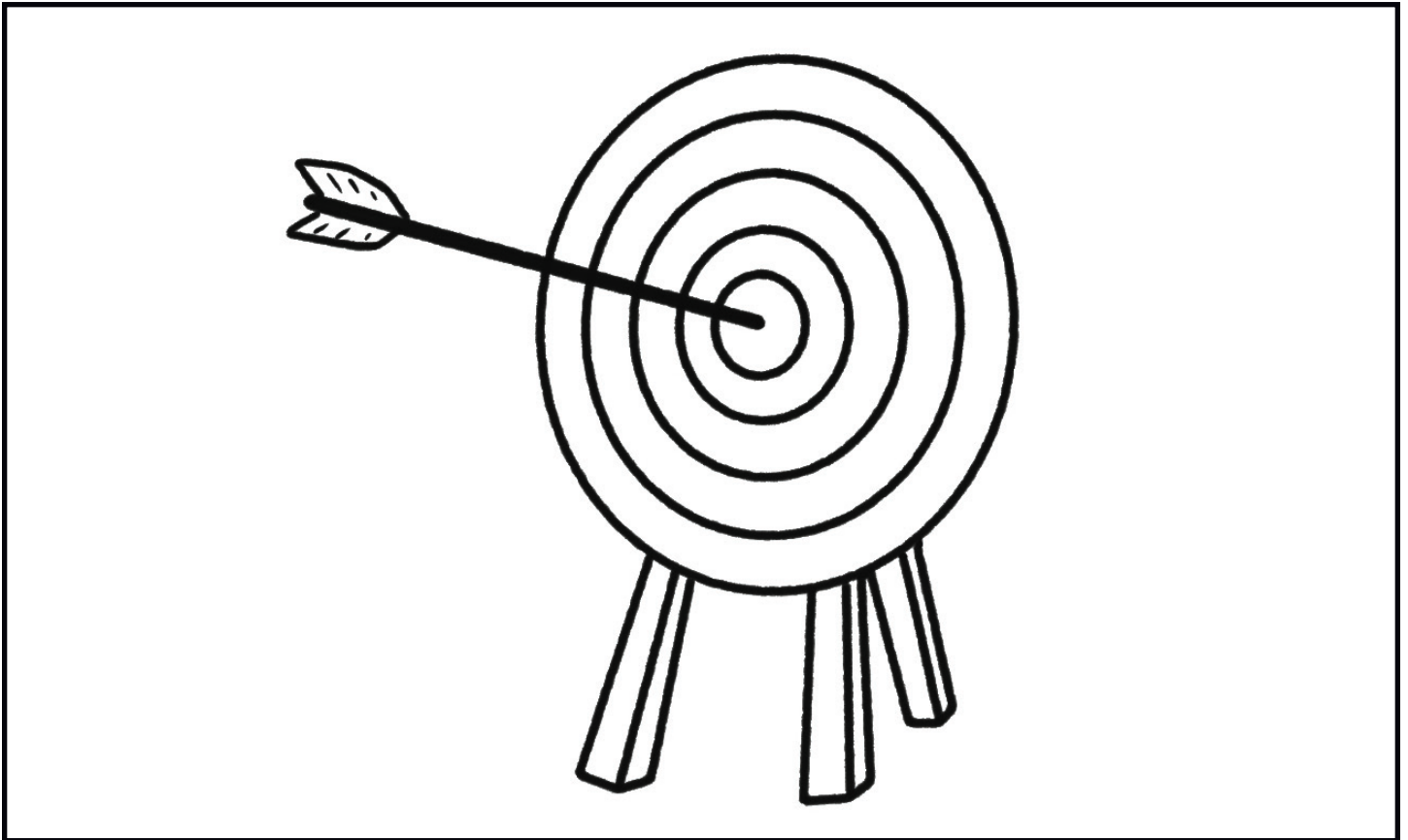

Color in the picture below.







Color in the  if the action shows hitting the mark.

Color in the  if the action shows missing the mark.

  sharing with others

  saying unkind words

  waiting patiently

  sneaking dessert before dinner

Draw a picture of an action that hits the mark and a picture of an action that misses the mark.

--	--

Read Romans 3:23. With the adult with you, discuss why all humans miss the mark.

Romans 3:23

All have sinned and fall short of the glory of God.

Scripture Memory

Genesis 1:27

So God created human beings in his image. In the image of God he created them. He created them male and female.

Game: Hit the Target



- On a large sheet of poster paper, draw a target. Then tape that target to the wall.
- Have your child stand roughly five feet from the target. Give him a soft ball and allow him to try to throw the ball and hit the target.
- If the ball hits the target, have him describe one action that hits the mark. If the ball misses the target, have him describe one action that misses the mark. Then say together, "All humans miss the mark."
- Every time your child hits the target with the ball, have him move back 1–2 feet for the next throw.
- Repeat until your child has thrown the ball at least six times.

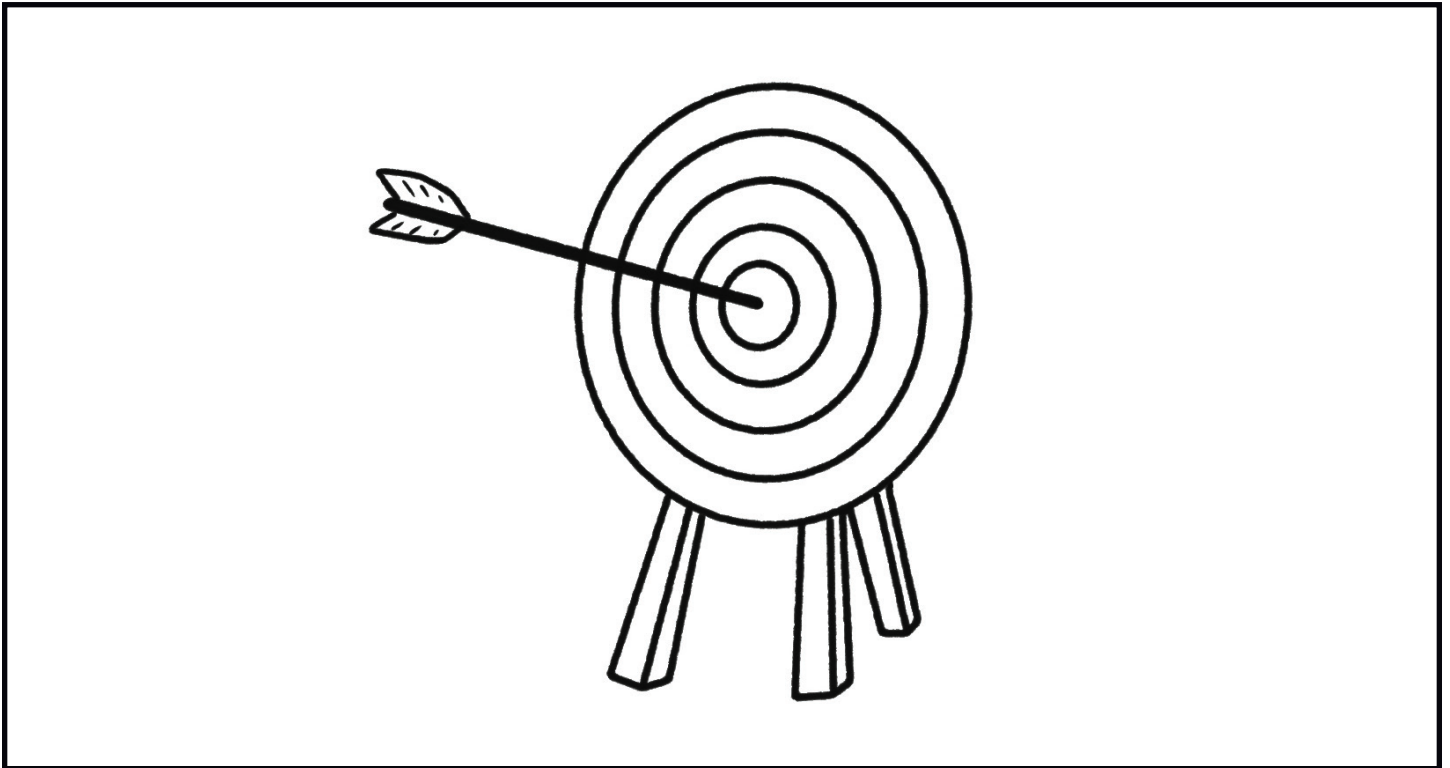

Unit 4 Lesson 5

Big Truth – Jesus hit the mark for us.

Color in the picture below.



Color in the  if the action shows Jesus hitting the mark for us. Color in the  if the action does not show Jesus hitting the mark for us.

  Jesus obeyed his parents.



Jesus loved others.



Jesus always spoke the truth.



Jesus obeyed all of God's laws.

Color in the picture below.

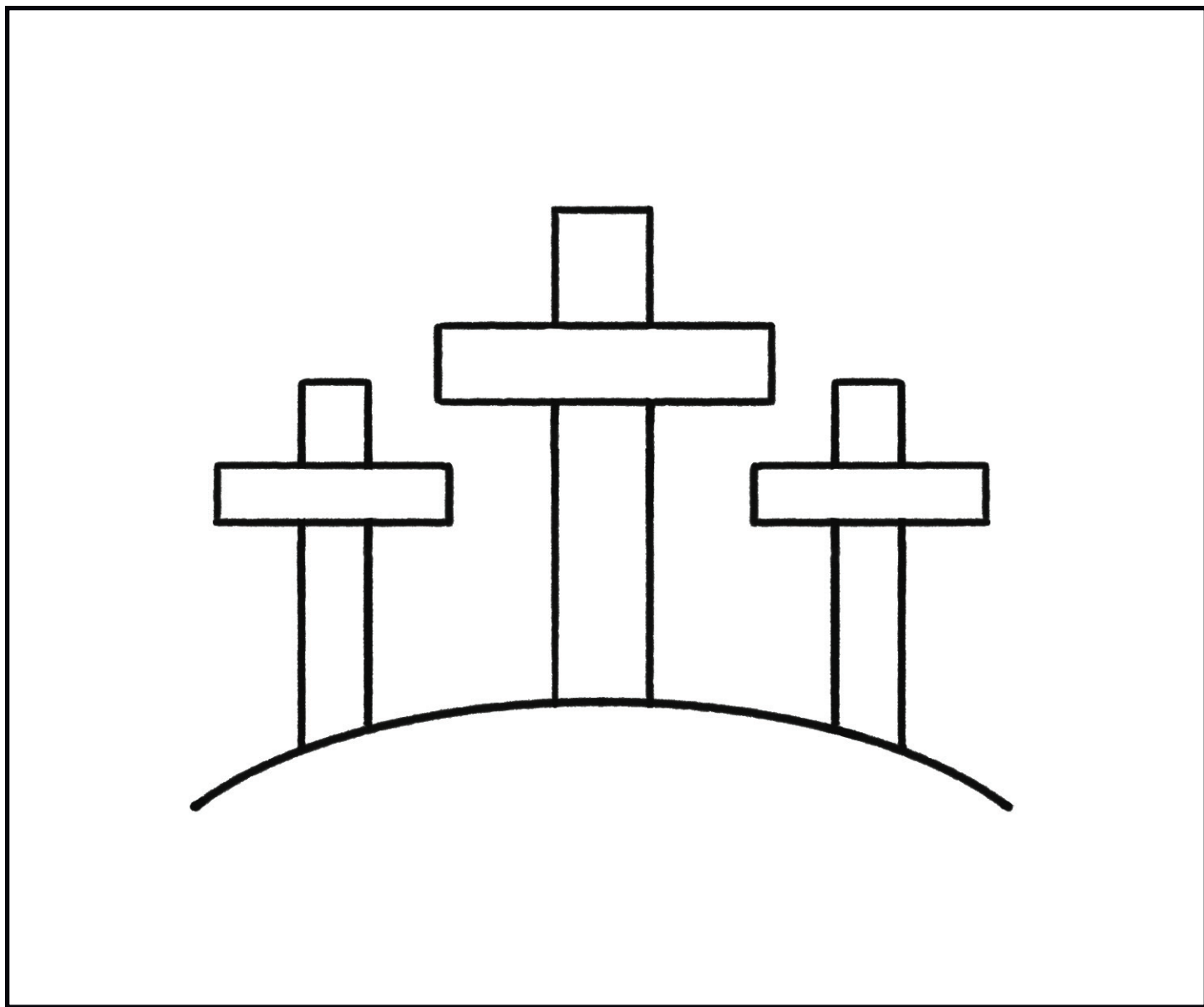

Read Romans 5:8 and then explain to the adult with you how the picture you colored in shows God's love for us.

Romans 5:8

But God shows his love for us in that while we were still sinners, Christ died for us.

Scripture Memory

Genesis 1:27

So God created human beings in his image. In the image of God he created them. He created them male and female.

Activity: Jesus Hit the Mark for Us

- Read the following Bible narratives to your child.
 - Mark 1:29–34
 - Mark 1:35–38
 - Mark 10:13–16
- Every time you read a sentence that describes Jesus doing something that honors God, have your child stand up and shout, “Jesus hit the mark for us!”

Song: "In His Image" (to the tune "O My Darling, Clementine")

"Let Us make man in our image,"
Said the Father, Spirit, Son.
We will make them male and female
And give them do-min-ion.

In the garden, He walked with them
Until one day, dark and grim
Male and female chose their own way
And the world was marred by sin.

But our God, in love and mercy,
Sent His Son to pay sin's price.
With His blood won our forgiveness
And secured eternal life.

Unit 5 Lesson 1

Big Truth – Right and wrong are truths, not feelings.

Color in the picture below.

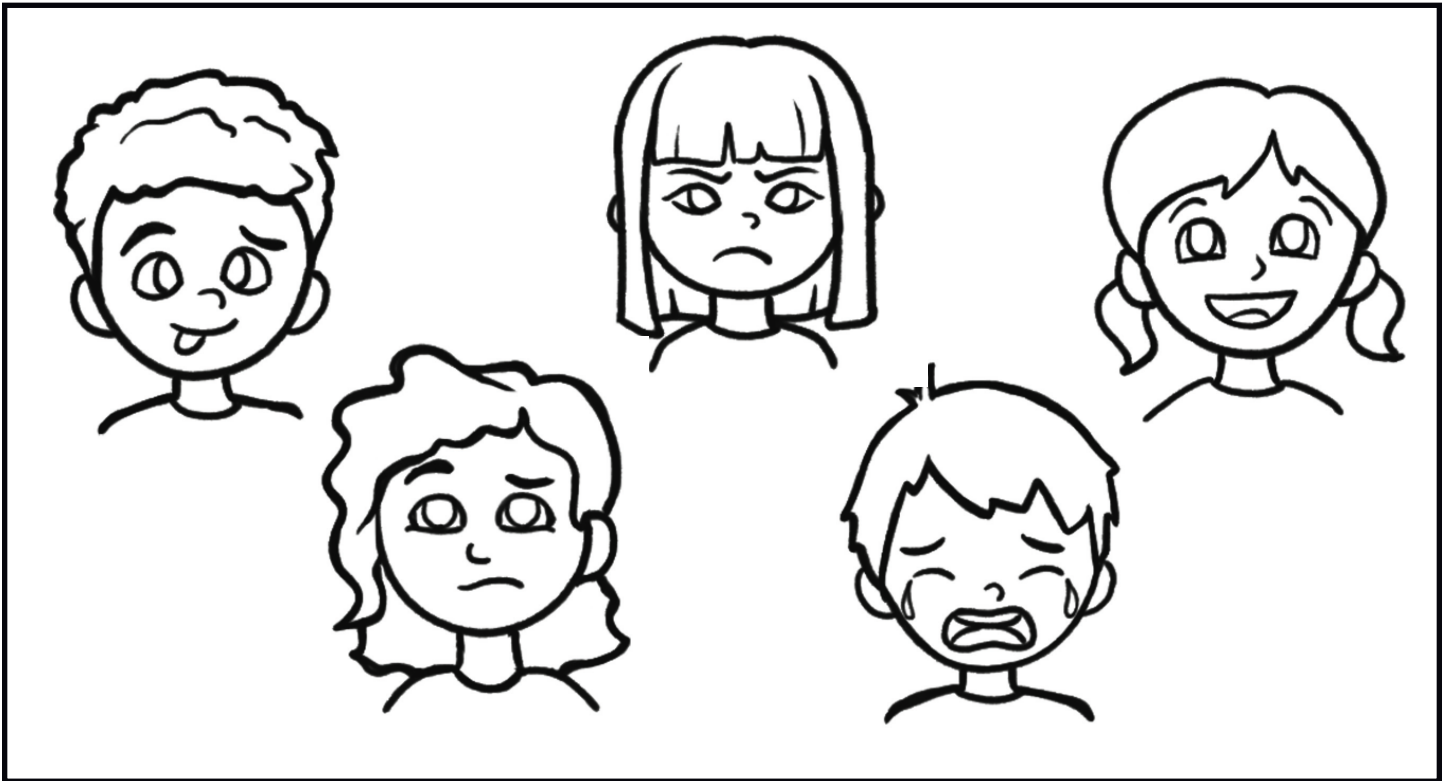

Color in the 😊 if the sentence is true. Color in the ❤️ if the sentence is a feeling.

😊 ❤️ Being kind is the right thing to do.

😊 ❤️ We should not push others down.



Obedying our parents is fun.



Telling the truth is hard.

Draw a picture of one right thing that you enjoy doing.

What if tomorrow you stopped liking this right thing?
Would your feelings about this right thing change it into a
wrong thing? Talk about this with the adult with you.

Scripture Memory

1 Peter 1:16

You must be holy, because I am holy.

Game: Truth of Feelings Race

- Stand in the middle of the room with your child.
- Say a sentence out loud that shows either a truth or feelings about right and wrong. (Sample sentences are given below.)
- If the sentence tells a truth, your child should run to the wall on one side of the room.
- If the sentence tells a feeling, your child should run to the wall on the other side of the room.

Sample Sentences



- Stealing is wrong. (truth)
- I don't like stealing. (feeling)
- We should be patient. (truth)
- Being patient is hard. (feeling)
- I don't like being patient. (feeling)
- Loving others is fun. (feeling)
- Loving others is the right thing to do. (truth)
- Forgiving is hard. (feeling)
- We should forgive others. (truth)
- Doing the right thing is fun. (feeling)

Unit 5 Lesson 2

Big Truth – Right and wrong are the same for everyone.

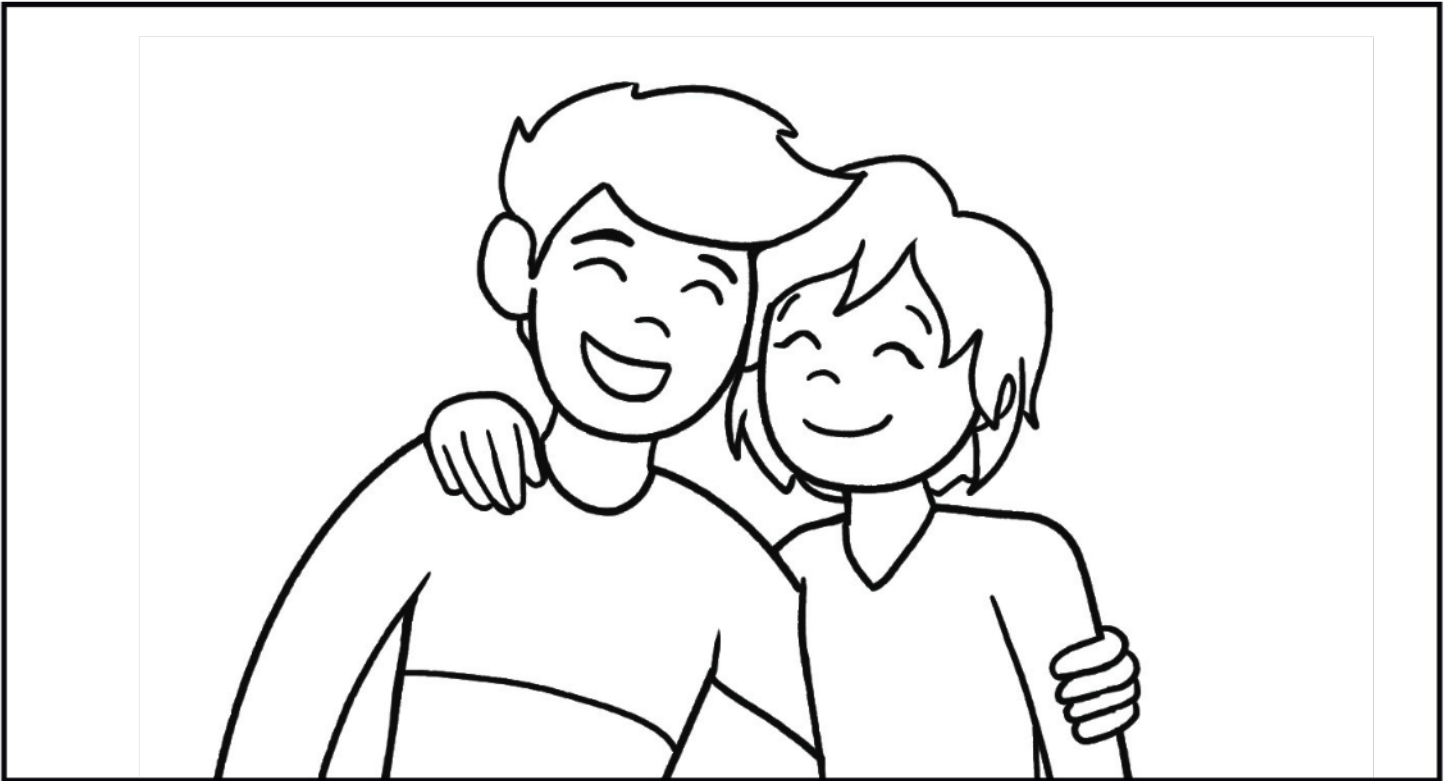
Color in the picture below.



Circle the  if the right thing is just for some people. Circle the  if the right thing is for everyone.



telling the truth



loving others

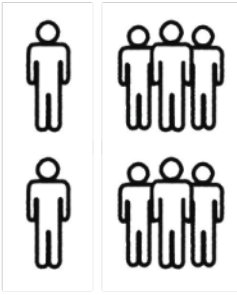

not stealing

speaking kind words

Draw a picture of a right action you have seen someone else do today.

A large, empty rectangular box with a black border, intended for a child to draw a picture of a right action they have seen someone else do today.

Talk with the adult with you about whether this right action is right just for some people or right for everyone.

Scripture Memory

1 Peter 1:16

You must be holy, because I am holy.

Game: Right and Wrong for Everyone Ball Bounce

- Find a ball that bounces.
- Stand across the room from your child and bounce the ball to her and say, “What is something that is right for everyone?”
- When she catches the ball, she should answer your question, describing an action that is right for everyone.
- She should then bounce the ball back to you and say either, “What is something that is right for everyone?” or “What is something that is wrong for everyone?”
- Repeat several times.

Unit 5 Lesson 3

Big Truth – God is the source of the rules for right and wrong.

Color in the picture that shows the source of each object.

Light

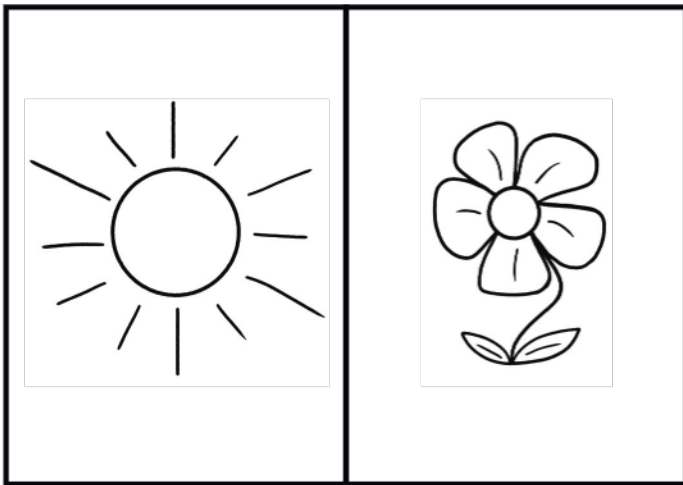

Eggs

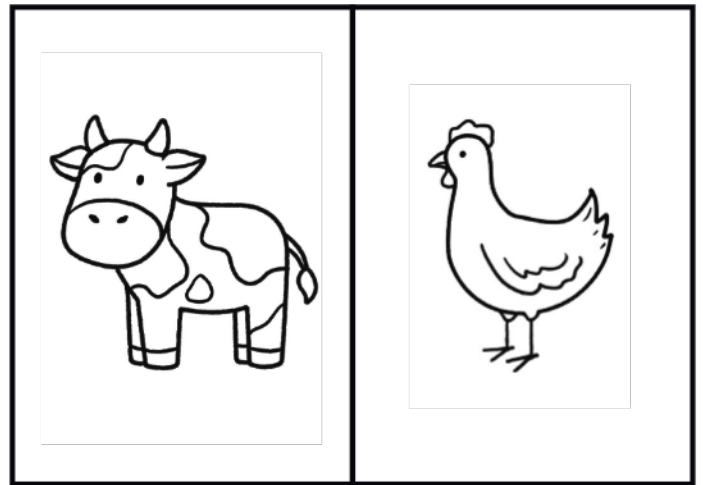

Rain

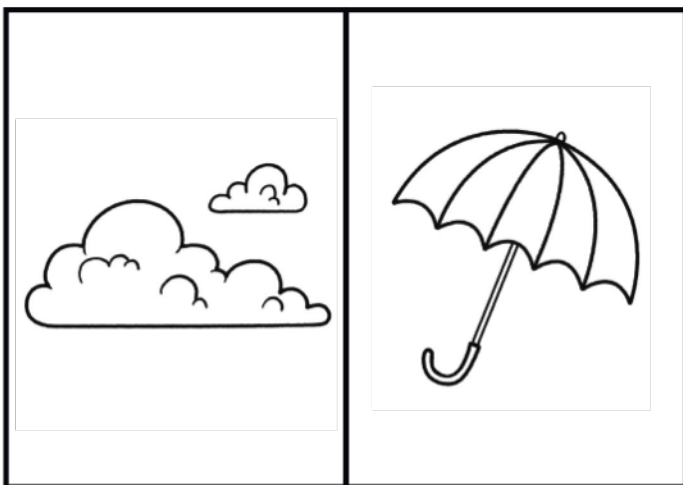

Rules for Right and Wrong

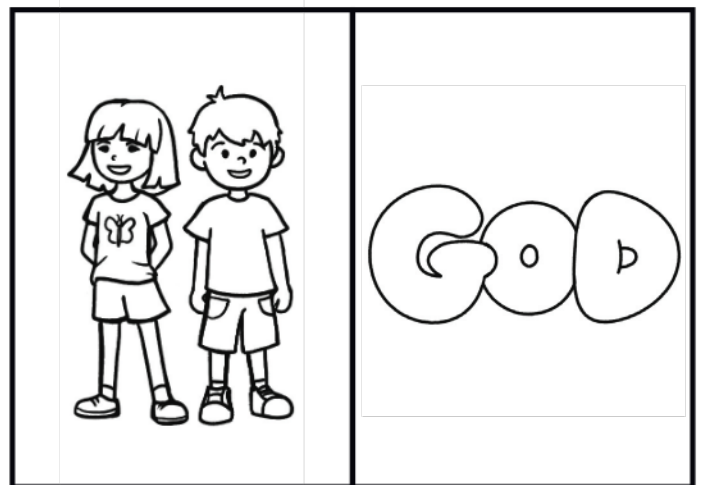

Draw a picture of a rule about right or wrong.

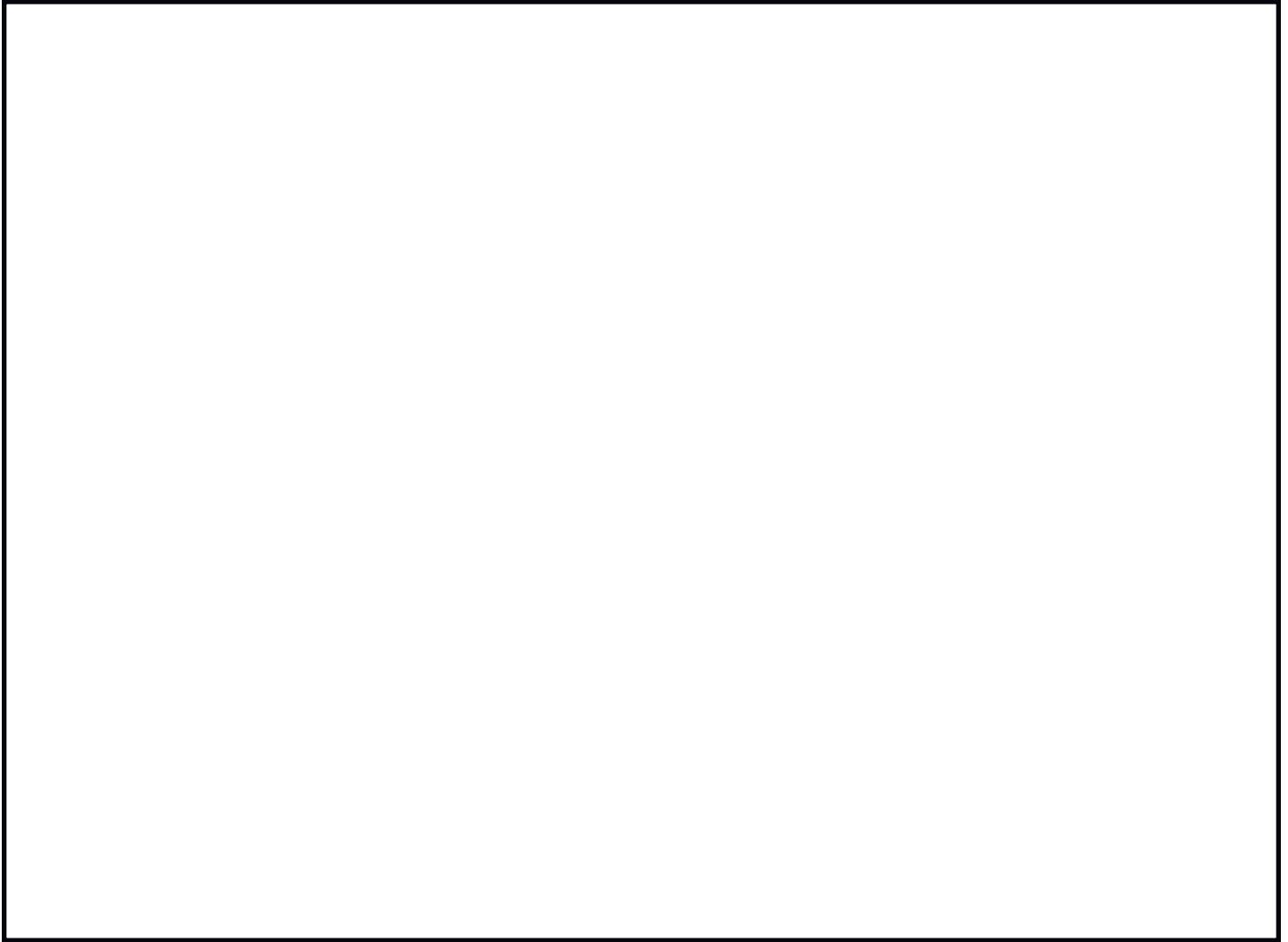

Tell the adult with you who or what is the source of that rule.

Scripture Memory

1 Peter 1:16

You must be holy, because I am holy.

Game: Is this the Source?

- Say a sentence from the list on the following page.
- If the sentence tells the true source of an object, have your child jump up, spread out her arms and shout, "True!"
- If the sentence does not tell the true source of an object, have your child cross his arms in front of him and shout, "Not true!" and then explain what the true source is.

Sentences



- God is the source of truth. (true)
- People are the source of the rules for right and wrong. (not true, God)
- Sheep are the source of wool. (true)
- Chickens are the source of milk. (not true, cows)
- The sun is the source of light. (true)
- God is the source of the rules for right and wrong. (true)
- Cows are the source of eggs. (not true, chickens)
- I am the source of truth. (not true, God)
- The clouds are the source of rain. (true)
- The government is the source of the rules for right and wrong. (not true, God)

Unit 5 Lesson 4

Big Truth – Right comes from God’s character.

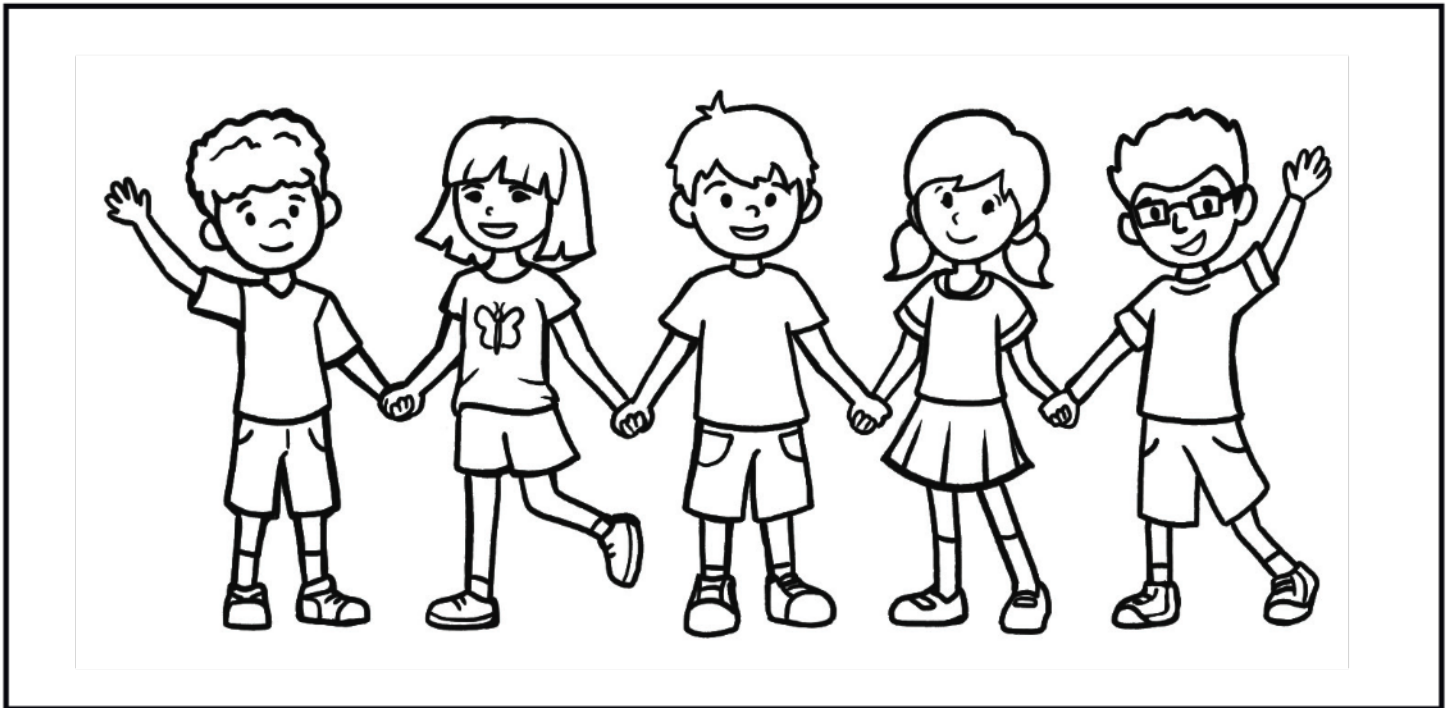
Color in the picture below.



Color in the  if the sentence describes something that goes along with God’s character. Color in the  if the sentence describes something that goes against God’s character.

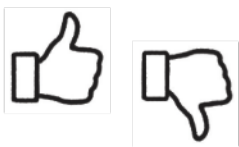

Sharing with your friend.



Speaking kind words to your friend.



Telling your friend the truth, even if it is hard.

Draw a picture of your family.

A large, empty rectangular box with a solid black border, intended for a child to draw a picture of their family.

Tell the adult with you three things your family can do that go along with God's character.

1. _____

2. _____

3. _____

Scripture Memory

1 Peter 1:16

You must be holy, because I am holy.

Game: Hit the Target

- On a large sheet of poster paper, draw a target. Then tape that target to the wall.
- Have your child stand roughly five feet from the target. Give him a soft ball and allow him to try to throw the ball and hit the target.
- If the ball hits the target, have him describe one action that hits the mark. Then say together, "Right comes from God's character."
- If the ball misses the target, have him describe one action that misses the mark. Then say together, "Right comes from God's character."
- Every time your child hits the target with the ball, have him move back 1–2 feet for the next throw.
- Repeat until your child has thrown the ball at least six times.

Song: "Right and Wrong"

(to the tune of "She'll Be Comin' 'Round the Mountain")

How do we know what's right and wrong to do?
And are right and wrong the same for me and you?
The Bible's rules are pretty clear
We do not need to fret or fear.
When we're not sure just look to God the Son.

What qualities does God the Son possess?
Truth and justice, mercy, love, and tenderness.
Full of grace and of compassion
Understanding, a man of action
As we look, He makes the truth of right so clear.

When our actions reflect Jesus, we can know
That we're doing right, and wrong's no way to go.
God's the source of right, not wrong
That's the message of this song
That He never changes, so right and wrong are clear.

Unit 5 Lesson 5

Big Truth – We learn right and wrong from God’s Word.

Color in the picture below.

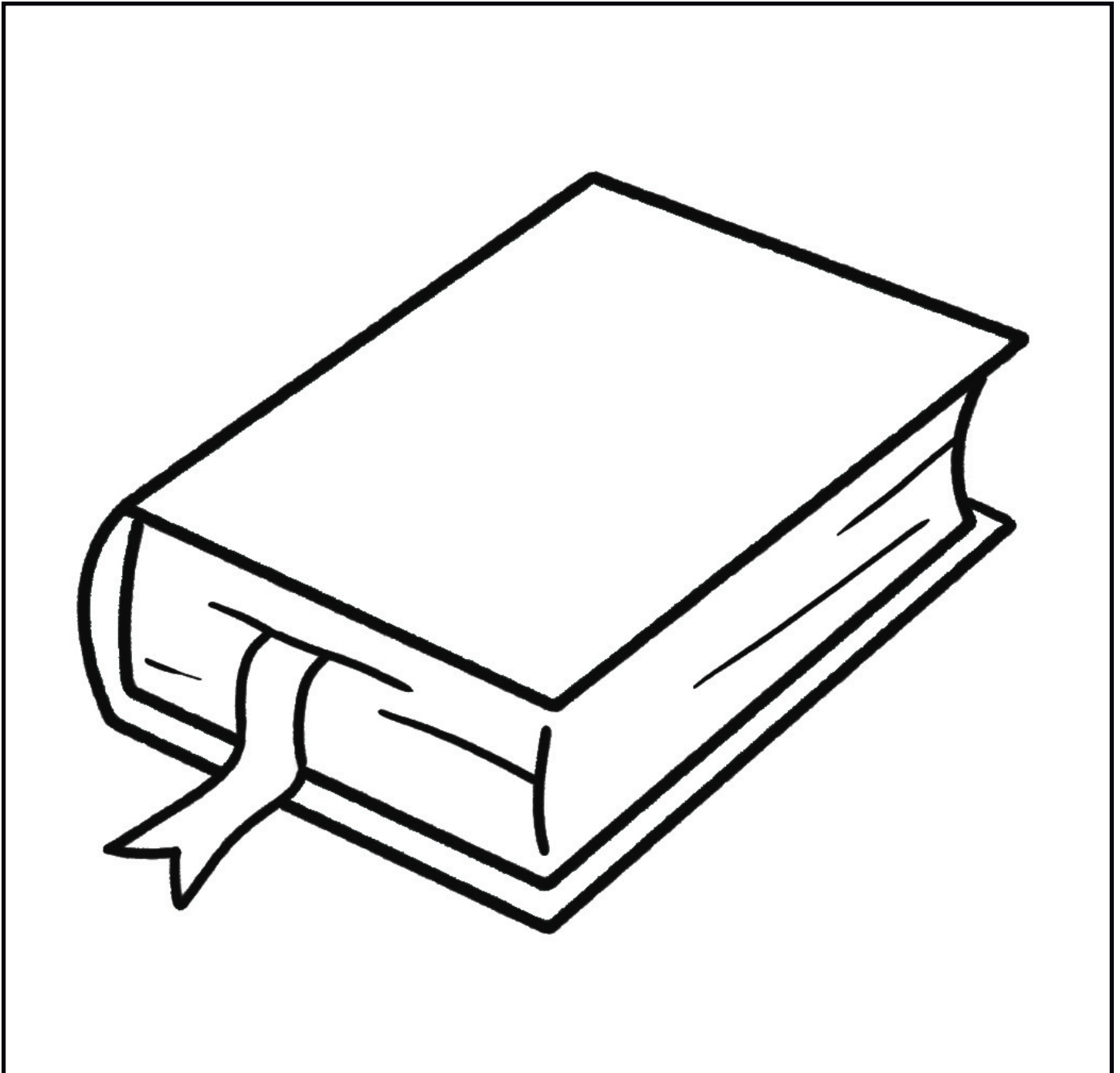

Read the verses below. Then draw a picture showing the things you learn about right and wrong from each verse.

1 Thessalonians 5:15

1 Thessalonians 5:16

--	--

1 Thessalonians 5:17

1 Thessalonians 5:18

--	--

Scripture Memory

1 Peter 1:16

You must be holy, because I am holy.

Game: Mother May I?

- Have your child stand at one end of the room while you stand at the other.
- Have your child ask, "Mother, may I take two giant steps?"
- Say a sentence from the list on the following page. If the sentence describes something that goes along with God's character, your child should say, "With God's character!" and take two giant steps forward. If the sentence describes something that goes against God's character, your child should say, "Against God's character!" and take one step backward.

Sentences

- Loving others (with God's character)
- Telling the truth (with God's character)
- Stealing (against God's character)
- Giving thanks (with God's character)
- Complaining (against God's character)
- Being fair (with God's character)
- Being kind (with God's character)
- Not honoring parents (against God's character)
- Making fun of others (against God's character)
- Caring for others (with God's character)
- Lying (against God's character)
- Standing up against evil (with God's character)